

TRACTORS TP200 - TP200L ELECTRICPORTER

FANTOZZI

moving safe. at work



General features and advantages

FANTOZZI TP200 borns to be an electric tractor for loading/towing goods with pedestrian driver. FANTOZZI TP200L is the model with longer loading platform for those companies who need more loading space and ask for a quick, safe and efficient vehicle.

Intensive use

The high numbers of scheduled working handlings and meanwhile the unexpected emergencies and precision, need reliable tools always versatile and available to carry-out continuous work granting high quality levels. Slim and strong FANTOZZI TP200 & TP200L are suitable to drive into small and complex ways; working proof resistant inside the stocking area and factory on flat floors.

Increase on productivity

FANTOZZI TP200 & TP200L tractors answer the modern concept of logistic, goods handling and people's transport which require more and more skilled and dedicated working instruments suitable to reach the best compromise between working time, working quality/precision, and operator's safety/satisfaction.

During handling of unpacked goods or single pieces - without pallets or loading units - FANTOZZI TP200 & TP200L produce a significant increase in productivity, it means much more work arranged shortly and saving of human resources.

Driving comfort

FANTOZZI TP200 & TP200L have comfortable pedestrian driving position, thanks to the ergonomic tiller handle and the great flexibility.

The driving control unit that can be operated with thumbs is placed inside the tiller for easier switch on/off.

By driving the TP200 & TP200L tractors, the operator stands longtime on safety and correct position while the loading/unloading operations are easier, thanks to the vehicle's handiness and the limited platform height.



Maximum safety for operator, goods and environment
The modern concept of safety is not only limited to the operator but to the complete "system": operator, goods, environment.

FANTOZZI TP200 & TP200L are studied in accordance with current regulations as for accident-prevention, limited vibrations, industrial health, common protection etc, but mainly thinking on ethic responsibility and reliability as for working satisfaction and appreciation of human resources.

Technical / manufacturing features

Motor

Equipped with 300W motor - Speed 8 Km/h - Loading capacity up to 100 Kg (model TP200L) - Towing capacity 200 Kg. max. (On request: 500W motor for driving on important grades).



Speed reducer

3 different reducing ratios are available: they allow the driving capacity on grades and speed capacity on long distances.

Chassis

Strong structure made of Fe37 with black embossing non-scratch epoxy painting. The structure reinforcements guarantee the maximum vehicle's reliability.



Electronic control unit

The electronic control unit allows the speed, braking, acceleration adjustments: these parameters customize the use of FANTOZZI Tractors.

Battery

TP200 & TP200L are equipped with two traction batteries 12V 51Ah (no battery maintenance), for 6 hours endurance. All kinds of batteries do not release fumes during the charge.

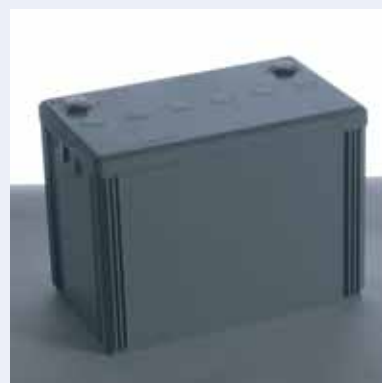

Built-in battery charger

Built-in inside the vehicle, it allows everywhere quickly recharge and without additional costly devices.

Tiller handle

Easy-to-use, simple and ergonomic, the tiller handle includes:

- forward/backward control switch
- warning buzzer
- emergency button for emergency stop
- switching-on key.



Puncture-proof wheel

FANTOZZI TP200 & TP200L are equipped with puncture-proof wheels. Tyres are made by special superelastic rubber mix studied to reach the maximum safety for the vehicle.



Towing hook

Painted iron towing hook complete with bolts and nuts for fixing.



Enlarged battery compartment

FANTOZZI TP200 & TP200L are equipped with enlarged battery compartment in order to allow higher endurance (6 hours approx.).



Flexible tiller joint

Joint studied and manufactured for double operation: 45° inclination: starts the vehicle; straight position: stops the vehicle.



Platform

No slipping aluminium platform 380 mm, (900 mm model TP200L), allows the loading of small references, adding surplus to the operator's job.



Technical features

VDI 2198

Features	1.1	Manufacturer	Fantozzi	Fantozzi
	1.2	Model	TP200	TP200L
	1.3	Traction	Electric	Electric
	1.4	Type of driving	Pedestrian driver	Pedestrian driver
	1.5	Loading capacity	Q (t)	2
	1.9	Wheel axis	y (mm)	720
Weights	2.1	Weight including batteries	Kg	127
				150
Wheels / structure	3.1	Tyres (superelastic, pneumatic..)	SE	SE
	3.2	Front wheel dimensions	3.00 - 4	3.00 - 4
	3.3	Rear wheel dimensions	Ø 225	Ø 225
	3.5	Front wheel number (x = traction)	1	1
	3.5.1	Rear wheel number (x = traction)	2	2
	3.7	Rear wheel track	b ₁₁ (mm)	430
				430
Basic dimensions	4.7	Operator's protection height (cab)	h ₆ (mm)	1270
	4.8	Operator's seat height (cab)	h ₆ (mm)	/
	4.12	Towing hook height	h ₁₀ (mm)	90
	4.13	Platform height (without loading)	h ₁₁ (mm)	210
	*****	Clearance	h ₁₁ (mm)	115
	4.16	Loading platform length	l ₃ (mm)	380
	4.17	Loading platform width	b ₉ (mm)	520
	4.19	Total length	l ₁ (mm)	1020
	4.21	Total width	b ₁ (mm)	520
		Working aisle width	(mm)	900
		Intersecting aisle width	(mm)	1300
		Minimum rack width between 2 working aisles	(mm)	800
		90° Turning radius	(Wa mm)	1600
			2440	
* Performances	5.1	Driving speed with full loading	km/h	4
	5.1.1	Driving speed without loading	km/h	4
	5.8	Max. grade with full loading	%	19
	5.10	Service brake	Electromechanical + Mechanical	Electromechanical
	5.11	Parking brake	Electromechanical	Electromechanical
		Emergency brake	Electromechanical	Electromechanical
Electric motor		Driver detection sensor	Mechanical	Mechanical
	6.1	Traction motor - capacity KB 60 min	kW	0,3
	6.3	Battery	12V 51Ah	12V 51Ah
	6.4	Battery tension	U V	12V
	6.4.1	Battery capacity	K 5 Ah	51Ah
	6.5	Battery weight	Kg	2 x 22,5
Others	8.1	Kind of transmission	1:32	1:32
	8.4	Average noise for the operator	dB (A)	< 70
	8.5	Towing hook	Manual	Manual
	8.6	Steering gear	Mechanical	Mechanical
		Vibration to the operator	/	Mechanical

* the performances refer to the vehicle in perfect conditions, with charged battery and regular motor maintenance

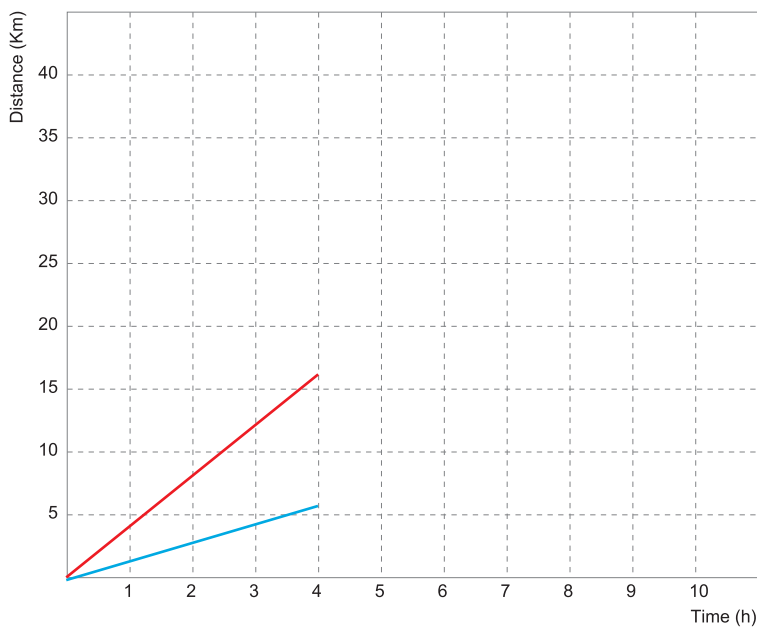
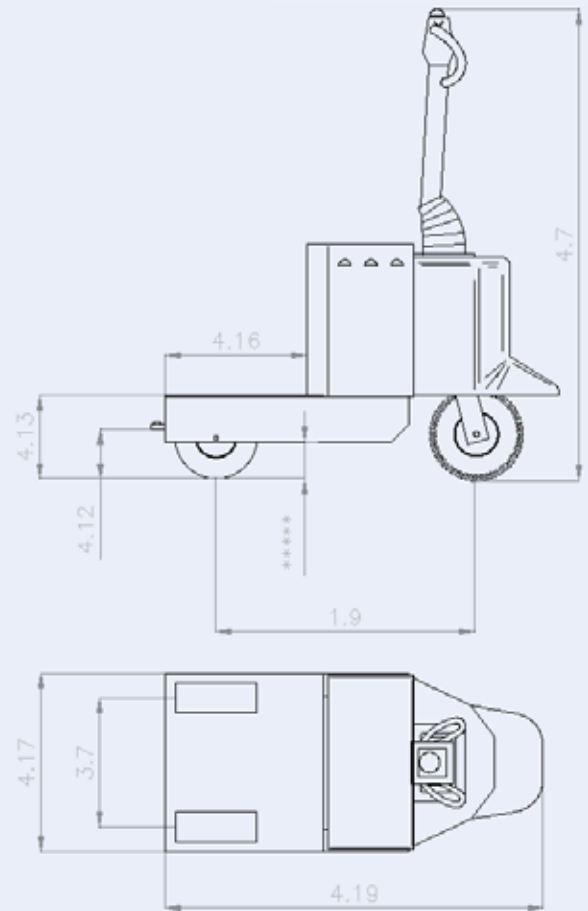
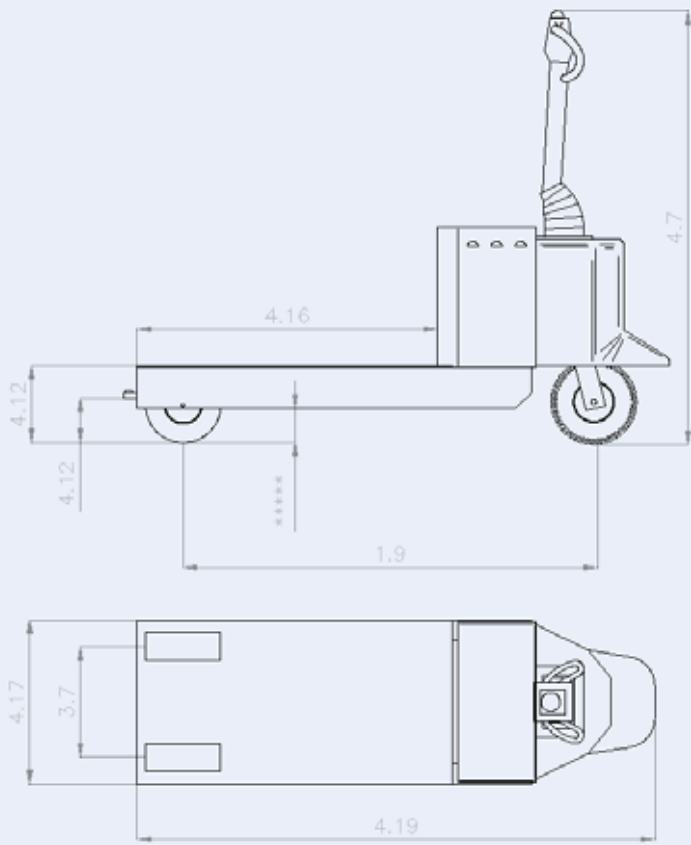

Easy and safe movement Production increased.

Always walking effortless.
There is just one difference
between a walking man and a
walking man driving a TP200:
300 Kg. towed effortlessly and
without risks at 4 Km/h.

— Walking man
— TP200

Safe working. You can! You must!

ELECTRICPORTER RANGE 2007



TRACTORS



PLATFORMS



SCOOTERS



HOSPITAL



EC CERTIFICATION



IN ACCORDANCE WITH 626 LAW



1000 Kg. MAXIMUM LOADING



80 cm. WAY WIDTH



2500 Kg. TOWING CAPACITY

FANTOZZI

moving safe. at work

Fantozzi Electric Carts S.r.l.
Via Rosa Luxemburg, 24
42010 Rio Saliceto (RE) - Italy
Tel. +39 0522 647192
Fax +39 0522 699479
info@fantozzi.com
sales@fantozzi.com
www.fantozzi.com