

Strength in the electric lifting

The HX 10E series offers great reliability and practicality thanks to the innovative new frontal protection and the reduced weight. The truck allows electric lifting of weights to a height of 800mm, it creates a useful adjustable working platform suitable for places such as workshops. It can also be used to support other machines in production, picking and similar areas.

Batter and External Battery Charger Supplied as Standard



12 months warranty

Auto Levelling System (Upon request)



- An automatic system that uses sensors to adjust the forks, maintaining a constant working height
- An acoustic-visual signal represents every movement of the forks
- Possibility of regulation of the photo cell both in height and in the reading angle
- A micro switch disconnects the power if the forks should stop running during lifting or lowering - both to reduce the battery energy consumption and to safeguard the operator

At a height of over 400mm, the rear stabilizers make the HX 10E a very safe and steady working platform, preventing rocking and movement in all directions.

Stabilizers



Front protection

- smaller dimensions allowing operator foot safety
- formed steel cover shielding wheels and the hydraulic unit
- protective top cover made in ABS shock resistant plastic
- shielding the battery
- redesigned and improved battery support

CODE				EF042000	EF044000
CODE UK				EF042400	EF044400
MODEL				HX 10E	HX 10E
CAPACITY	Q	Load capacity	Kg	1000	1000
DRIVING SYSTEM		Escort		●	●
DIMENSIONS					
ELEVATION	h3	Total elevation	mm	800	800
	h2	Normal free elevation	mm	400	400
LENGTH	l	Fork length	mm	1150	1150
	nxS1	Fork width x thickness	mm	160x48	160x48
	L	Total Length	mm	1685	1685
	B	Width	mm	540	680
TURNING RADIUS	Wa		mm	1445	1445
STOWAGE PASSAGE	Ast	800x1200	mm	1945	1945
WHEELS					
		Driver/load side	Nr	2/2	2/2
		Driver/load side	*	G/P	G/P
ELECTRICAL EQUIPMENT					
BATTERY		Voltage / capacity	V/Ah	12/60	12/60
CHARGER		Voltage / capacity	V/Ah	12/10	12/10
ELECTRIC MOTOR		Lifting motor	kW	1,6	1,6

* G=Rubber, P=Polyurethane

ACCESSORIES	
FRONT STABILIZERS	
CODE	EY000A0000A

Polyurethane load rollers as standard

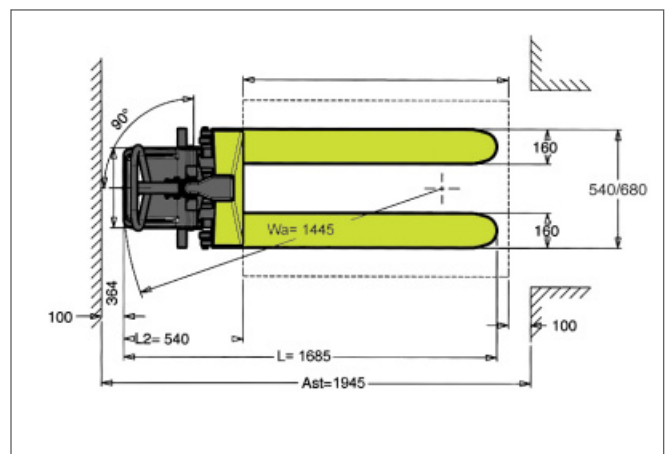
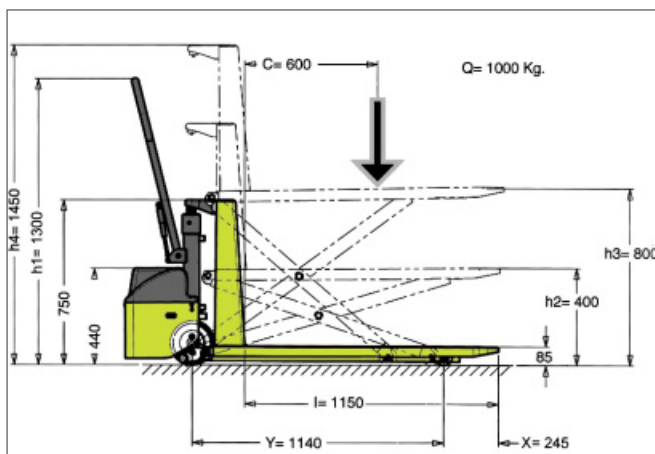

The producer reserves the right to introduce changes to models and features without prior notice.