

Strength in the manual lifting

The HX 10M series allows easier and lighter manual lifting up to a height of 800mm, creating a useful workbench suitable for places like mechanical workshops. It can also be used to support other machines in production, picking and similar areas.



12 months warranty

The front stabilizers improve its balance, making the work easier even when lifting and working with heavy loads.

Front stabilizers (optional)

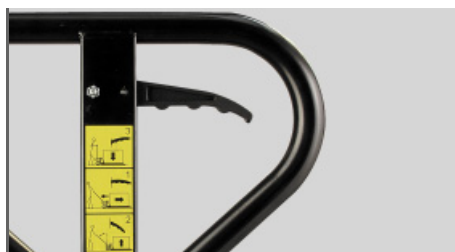

Control lever

All the controls (lowering / neutral / lifting) are available in a single lever for simple and safe control.

At a height of over 400mm, the rear stabilizers make the HX 10M a very safe and steady working platform, preventing rocking and movement in all directions.

Rear stabilizers

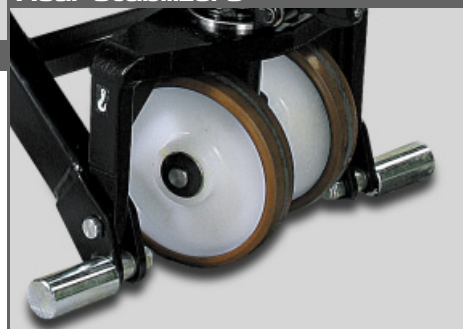

CODE				GT042000	GT044000
MODEL				HX 10M	HX 10M
CAPACITY	Q	Load capacity	Kg	1000	1000
DRIVING SYSTEM		Escort	type	●	●
DIMENSIONS					
ELEVATION	h3	Total elevation	mm	800	800
	h2	Normal free elevation	mm	400	400
LENGTH	l	Fork length	mm	1150	1150
	nxS1	Fork width x thickness	mm	160x48	160x48
	L	Total Length	mm	1526	1526
	B	Width	mm	540	680
TURNING RADIUS	Wa		mm	1340	1340
STOWAGE PASSAGE	Ast	800x1200	mm	1840	1840
WHEELS					
		Driver/load side	Nr	2/2	2/2
		Driver/load side	*	P/P	P/P

* G=Rubber, P=Polyurethane

ACCESSORIES	
FRONT STABILIZERS	
CODE	EY000A0000A

Polyurethane load rollers as standard

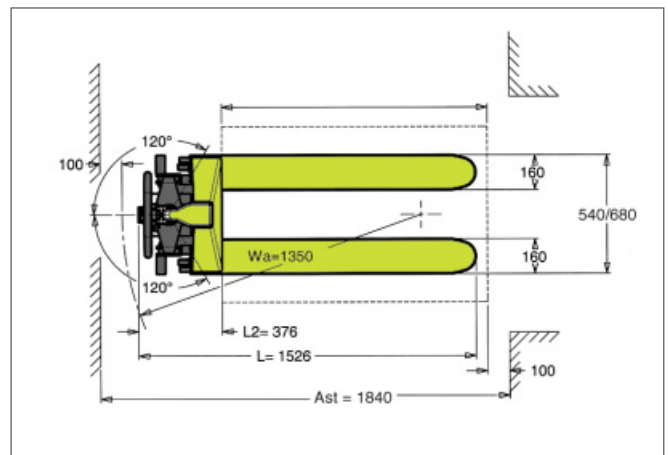
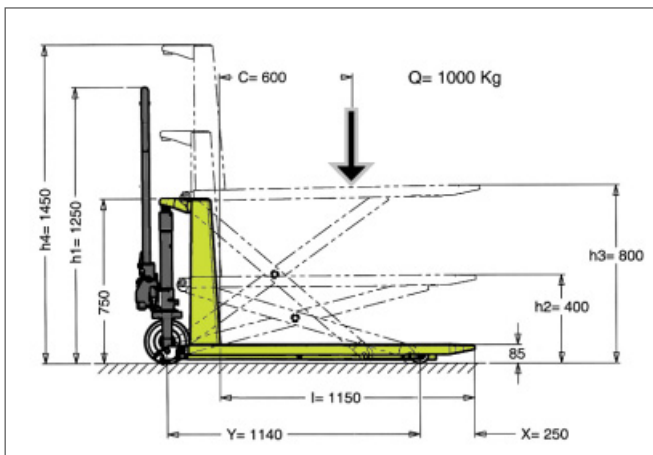

The producer reserves the right to introduce changes to models and features without prior notice.