

# Specifications

MODELS	SLC™-12		SLC™-18		SLC™-24	
MEASUREMENTS	US	Metric	US	Metric	US	Metric
Working height:						
standard forks - forks down	11 ft 2 in	3.40 m	16 ft 9 in	5.10 m	22 ft 3 in	6.78 m
standard forks - forks up	12 ft 11 in	3.94 m	18 ft 6 in	5.64 m	24 ft	7.32 m
adjustable forks - forks down	11 ft 2 in	3.40 m	16 ft 9 in	5.10 m	22 ft 3 in	6.78 m
adjustable forks - forks up	12 ft 11 in	3.94 m	18 ft 6 in	5.64 m	24 ft	7.32 m
boom**	12 ft 2 in	3.70 m	17 ft 9 in	5.41 m	23 ft 3 in	7.10 m
<b>A</b> Height - stowed	7 ft 2 in	2.18 m	7 ft 2 in	2.18 m	7 ft 2 in	2.18 m
<b>B</b> Length - stowed	2 ft 10 in	.86 m	2 ft 10 in	.86 m	2 ft 10 in	.86 m
<b>C</b> - operating	5 ft 3 in	1.60 m	6 ft 1 in	1.85 m	6 ft 9 in	2.06 m
<b>D</b> Width - stowed*	2 ft 7.5 in	.80 m	2 ft 7.5 in	.80 m	2 ft 7.5 in	.80 m
- with stabilizers lowered	5 ft 6 in	1.68 m	5 ft 6 in	1.68 m	5 ft 6 in	1.68 m

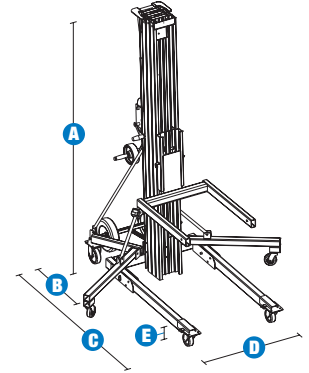

PRODUCTIVITY						
Load capacity:						
1 ft 2 in (.36 m) load center	650 lbs	295 kg	650 lbs	295 kg	650 lbs	295 kg
2 ft (.61 m) load center	425 lbs	193 kg	425 lbs	193 kg	425 lbs	193 kg
3 ft 6 in (1.07 m) load center	180 lbs	82 kg	160 lbs	73 kg	160 lbs	73 kg
<b>D</b> Ground clearance	2 in	.05 m	2 in	.05 m	2 in	.05 m
Load height minimum	6 in	.15 m	6 in	.15 m	6 in	.15 m

POWER						
Average cranks:						
standard winch	8.5 cranks/ft	27.8 cranks/m	8.5 cranks/ft	27.8 cranks/m	8.5 cranks/ft	27.8 cranks/m
two speed winch, high	4 cranks/ft	13.1 cranks/m	4 cranks/ft	13.1 cranks/m	4 cranks/ft	13.1 cranks/m
two speed winch, low	15 cranks/ft	49.2 cranks/m	15 cranks/ft	49.2 cranks/m	15 cranks/ft	49.2 cranks/m

WEIGHT						
	225 lbs	102 kg	307 lbs	139 kg	347 lbs	157 kg

LOAD HANDLING ATTACHMENTS				
MEASUREMENTS	US	Metric	Weight - US	Weight - Metric
Standard forks (l/w/d)***	28/23/2.5 in	71/58/6 cm	26.5 lbs.	12 kg
Adjustable forks (l/w/d)***	27.5/11-30/2.5 in	70/28-76/6 cm	52.5 lbs.	24 kg
Fork extensions detached (each) (l/w/d)***	30/2/3 in	76/5/8 cm	4.5 lbs	2 kg
Fork extensions attached (each) (l/w/d)***	25/2/3 in	64/5/8 cm	4.5 lbs	2 kg
Boom (l/w/d)***	18-42/1.5/6 in	46-107/4/15 cm	39.9 lbs	18 kg
Pipe cradle (l/w/d)***/****	27.5/24/6 in	70/61/15 cm	10 lbs	4.5 kg
Load platform (l/w/d)***	26.3/23/2.5 in	67/58/6 cm	31.5 lbs	14 kg

\* Outside dimensions.  
 \*\* Measured from ground to bottom of shackle.  
 \*\*\* Length/Width/Depth.  
 \*\*\*\* Handles round objects up to 30 in (76 cm) in diameter.

## Features

### EASILY CONFIGURED TO MEET YOUR NEEDS

#### PLATFORM OPTIONS

- Boom
- Standard forks
- Adjustable forks
- Fork extensions
- Pipe cradle
- Load platform

#### POWER OPTIONS

- One speed winch
- Two speed winch

#### BASE OPTIONS

- Standard base
- Stabilizer set

#### CASTER & BRAKE OPTIONS

- 4 in (10 cm) front casters
- 5 in (13 cm) rear casters with side brakes

### STANDARD FEATURES

#### MEASUREMENTS

##### SLC™-12

- 12 ft 11 in (3.94 m) working height
- Up to 650 lb (295 kg) lift capacity

##### SLC™-18

- 18 ft 6 in (5.64 m) working height
- Up to 650 lb (295 kg) lift capacity

##### SLC™-24

- 24 ft (7.32 m) working height
- Up to 650 lb (295 kg) lift capacity

#### PRODUCTIVITY

- Standard forks
- Heavy-duty design
- Strong, lightweight aluminum telescoping mast
- Single door access
- Quick set up requires no tools
- Interchangeable load handling attachments
- Non-marking 4 in (10 cm) front casters and 5 in (13 cm) rear casters with side brakes
- Rear transport wheel assembly
- Glide rails allow easy loading and unloading, on or off a vehicle, for transport
- Hold-down bar secures mast assembly during transport
- Captive stabilizer set (standard on SLC™-18, -24)

#### POWER

- One speed winch



### OPTIONS & ACCESSORIES

#### PRODUCTIVITY

- Boom
- Adjustable forks
- Fork extensions
- Pipe cradle
- Load platform
- Stabilizer set (option on SLC™-12)

#### POWER

- Two speed winch

### Genie United States

18340 NE 76th Street  
P.O. Box 97030  
Redmond, Washington 98073-9730

Telephone **(425) 881-1800**  
Toll Free in USA/Canada **800-536-1800**  
Fax (425) 883-3475

### Genie Europe

The Maltings  
Wharf Road  
Grantham NG31 6BH  
U.K.

Telephone **+44 (0)1476 584333**  
Fax +44 (0)1476 584334

Email: [infoeurope@genieind.com](mailto:infoeurope@genieind.com)

### Distributed By:

Effective Date: July, 2007. Product specifications and prices are subject to change without notice or obligation. The photographs and/or drawings in this document are for illustrative purposes only. Refer to the appropriate Operator's Manual for instructions on the proper use of this equipment. Failure to follow the appropriate Operator's Manual when using our equipment or to otherwise act irresponsibly may result in serious injury or death. The only warranty applicable to our equipment is the standard written warranty applicable to the particular product and sale and we make no other warranty, express or implied. Products and services listed may be trademarks, service marks or trade-names of Terex Corporation, Genie Industries, Inc. and/or their subsidiaries in the U.S.A. and many other countries. All rights are reserved. Terex® is a Registered Trademark of Terex Corporation in the U.S.A. and many other countries. Genie® and Superlift Contractor® are Registered Trademarks of Genie Industries, Inc. in the U.S.A. and many other countries. Genie is a Terex Company. Copyright © 2007 Terex Corporation.

SLC 3.5K 0707F. Part No. 109321

[www.genieindustries.com](http://www.genieindustries.com)