

# GS

## GS BASIC GS PRO, GS SPECIAL GS PREMIUM, GS SILENCE

### GS BASIC

The GS basic pallet truck is the model of access to the range of Lifter hand pallet trucks with which it shares reliability and solidity. Available with fork length 800 and 1.150 mm.

### GS PRO, SPECIAL \*

The GS pro pallet truck is equipped as a standard with a start and exit roller and a more ergonomic handle. The special series allows for the handling of pallets of any size thanks to the great variety of frames. The new 3.000 Kg model offers a load capacity of 3.000 Kilograms thanks to its reinforced structure.

### GS PREMIUM \*

The GS premium pallet truck offers innovative cutting-edge solutions, such as the tilt guide wheel, the load lowering speed control, the covered steering wheel, apart from a certified hydraulic unit for 50.000 Cycles.

### GS SILENCE \*

The GS Silenced hand pallet truck has been designed to strongly reduce the noise emission even in the worse working condition: rough and tiled surfaces. The result is an ideal machine for the usage on residential areas, deliveries and in supermarket stores.

GS series is a suitable practical solution meeting all the needs of manual handling.

For the transport of fragile and delicate loads, such as loads of glass or ceramics, the premium version includes a sensitive and safe forks lowering control system.

The special series, with its broad choice of forks dimensions, guarantees solutions to handle any type of pallet; finally, the pro version, also available with a 3.000 Kg load capacity, completes the range of Lifter pallet trucks that are completely made in Italy.

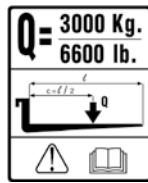

Available accessories: tandem rollers, polyurethane rollers (as a standard on Premium), rubber guide wheels, manual control brake



**MAXIMUM PRESSURE VALVE**  
When the maximum load capacity is exceeded, oil pressure exceeds its maximum limit and the valve automatically locks the forks. Thus possible structural damage is avoided.



**PAINTING**  
Following an appropriate conditioning operation the frame is varnished with epoxy-polyester powder at a temperature of 250° to guarantee maximum resistance to wear and atmospheric agents.

# Manual Trucks

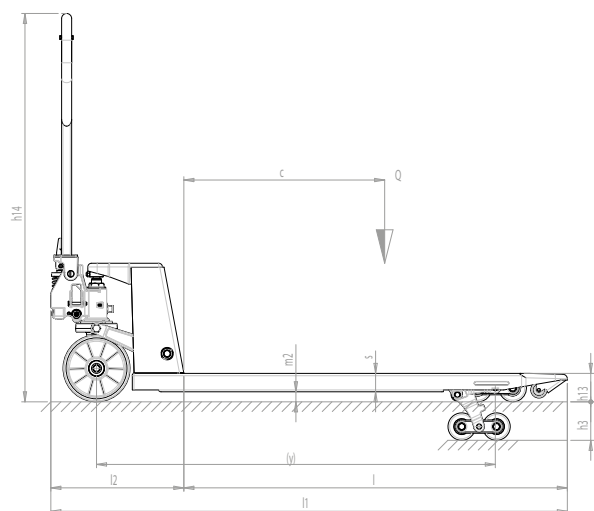
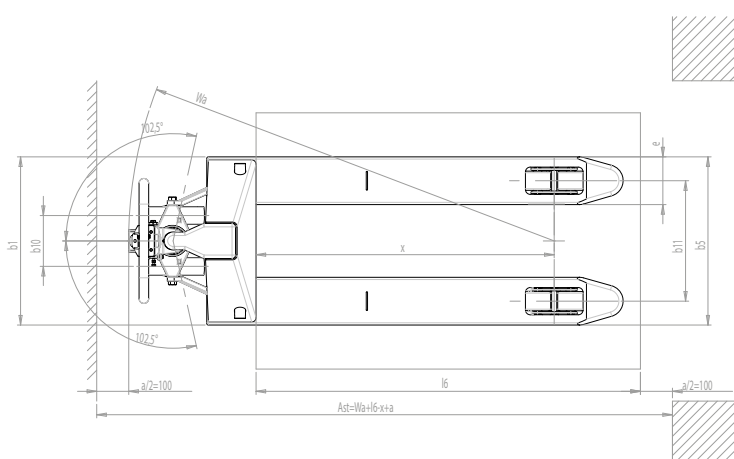

## DESCRIPTION

1.2 MODEL	GS BASIC 22 S2-S4	GS PRO 25 S2-S4	GS PREMIUM 25 S2-S4	GS/AV PRO 25 S2-S4	GS PRO 30 S4	GS/L PRO 25 S2-S4	GS/M PRO 25 S2-S4	GS B 20 S4
1.3 DRIVE	MANUAL	MANUAL	MANUAL	MANUAL	MANUAL	MANUAL	MANUAL	MANUAL
1.4 OPERATOR TYPE	PEDESTRIAN	PEDESTRIAN	PEDESTRIAN	PEDESTRIAN	PEDESTRIAN	PEDESTRIAN	PEDESTRIAN	PEDESTRIAN
1.5 LOAD CAPACITY	Q kg	2200	2500	2500	2500	3000	2500	2000
1.6 LOAD CENTRE DISTANCE	c mm	600	600	600	600	600	400	600
1.8 LOAD DISTANCE, CENTRE OF DRIVE AXLE TO FORK	x mm	932	932	932	932	932	582	945
1.9 WHEEL BASE	y mm	1192	1192	1192	1192	1192	842	1192

## WEIGHTS

2.1 SERVICE WEIGHT	kg	61-63	61-63	63-65	61-63	79	66-68	52-54	71
2.2 AXLE LOAD LADEN, FRONT/REAR	kg	655/1606-1608	767/1794-1796	739/1824-1826	738/1823-1825	889/2190	771/1795-1797	691/1861-1863	693/1378
2.3 AXLE LOAD UNLADEN, FRONT/REAR	kg	42/19-21	42/19-21	43/20-22	42/19-21	53/26	46/20-22	35/17-19	48/23

## TYRES/CHASSIS

3.1 TYRES		P/N	P/N	P/P	P/N	P/N	P/N	P/N	P/A
3.2 TYRE SIZE, FRONT (Ø x width)		200x45	200x55	200x55	200x55	200x55	200x55	200x55	200x55
3.3 TYRE SIZE, REAR (Ø x width)		82x82-60	82x82-60	82x82-60	82x82-60	82x60	82x82-60	82x82-60	50x58
3.4 SIDE WHEELS (Ø x width)		-	-	-	-	-	-	-	-
3.5 WHEELS, NUMBER (x=DRIVEN) FRONT/REAR		2/2-2/4	2/2-2/4	2/2-2/4	2/2-2/4	2/4	2/2-2/4	2/2-2/4	2/4
3.6 TREAD, FRONT	b10 mm	155	155	155	155	155	155	155	130
3.7 TREAD, REAR	b11 mm	375	375	375	375	375	535	250	365

## DIMENSIONS

4.4 LIFT	h3 mm	115	115	115	115	115	115	115	115
4.9 HEIGHT OF TILLER IN DRIVE POSITION MIN/MAX	h14 mm	690/1160	690/1160	690/1160	415/1250	690/1160	690/1160	690/1160	690/1160
4.15 HEIGHT, LOWERED	h13 mm	85	85	85	85	85	85	85	55
4.19 OVERALL LENGTH	l1 mm	1550	1550	1550	1550	1550	1550	1200	1550
4.20 LENGTH TO FACE OF FORKS	l2 mm	400	400	400	400	400	400	400	400
4.21 OVERALL WIDTH	b1 mm	525	525	525	525	525	685	400	525
4.22 FORK DIMENSIONS	s/e/l mm	55/150/1150	55/150/1150	55/150/1150	55/150/1150	55/150/1150	55/150/1150	55/150/800	40/160/1150
4.25 DISTANCE BETWEEN FORK ARMS	b5 mm	525	525	525	525	525	685	400	525
4.32 GROUND CLEARANCE, CENTRE OF WHEEL BASE	m2 mm	30	30	30	30	30	30	30	15
4.34 AISLE WIDTH FOR PALLETS 800x1200 LENGTHWISE	Ast mm	1835	1835	1835	1835	1835	1835	1435	1822
4.35 TURNING RADIUS	Wa mm	1367	1367	1367	1367	1367	1367	1017	1367

## PERFORMANCE DATA

5.2 LIFT SPEED, LADEN/UNLADEN	strokes	13/13	13/13	13/13	13/6	13/13	13/13	13/13	13/13
-------------------------------	---------	-------	-------	-------	------	-------	-------	-------	-------

G = Rubber, N = Nylon, P = Polyurethane, A = Steel, NE = Nylon extra

FORK LENGTH	l	mm	600	800	950	1000	1150	1220	1350	1500	1800	2000
LOAD CENTRE DISTANCE	c	mm	300	400	475	500	600	610	675	750	900	1000
WHEELS, NUMBER (x=DRIVEN) FRONT/REAR			2/2-2/4	2/2-2/4	2/2-2/4	2/2-2/4	2/2-2/4	2/2-2/4	2/4	2/4	2/4	2/4
OVERALL LENGTH	l1	mm	1000	1200	1350	1400	1550	1620	1750	1900	2200	2400
LOAD DISTANCE, CENTRE OF DRIVE AXLE TO FORK	x	mm	382	582	732	782	932	1002	1132	1282	1582	1782
WHEEL BASE	y	mm	642	842	992	1042	1192	1262	1392	1542	1842	2042
SERVICE WEIGHT	kg		52-54	57-59	59-61	60-62	63-65	65-67	90	112	127	134
AXLE LOAD LADEN, FRONT/REAR	kg		356/2196-2198	580/1017-1435	688/1871-1873	716/1844-1846	739/1824-1826	821/1744-1746	880/1710	929/1717	1002/1625	1037/1597
AXLE LOAD UNLADEN, FRONT/REAR	kg		37/15-17	40/17-19	40/19-21	39/21-23	43/20-22	44/21-23	59/31	66/46	76/51	80/54
TURNING RADIUS	Wa	mm	817	1017	1167	1217	1367	1437	1567	1717	2017	2217
AISLE WIDTH FOR PALLETS 800x1200-l LENGTHWISE	Ast	mm	1235	1435	1585	1635	1835	1855	1985	2135	2435	2635