

Versatility for Larger Loads

The Straddle Series, which is available in five versions fitted with MOSFET technology (GX series), is highly versatile when dealing with different size loads. These versions are fitted with gel batteries that will not possibly lose any battery fluid – meaning that no maintenance is necessary and suitable for all applications where high hygienic standards are required (chemical, pharmaceutical and food & beverage industries).

Batteries and battery charger built in

Available with a double fork lifting command (GX series)



12 months warranty

Tiller handle and controls

- Large butterfly control allows accurate speed and direction control.
- Battery discharge indicator.
- Safety button and horn are located on the top of the tiller head.
- Handle bar made of cubic iron sheet. The strong and easily removable plastic cover allows simple access to the inside parts for easier maintenance.



STACKERS

SERIES **GX and TX**
STRADDLE

CODE			HA310010	HC512010	HC712010	-	HC512110	HC712110	-	HC512310	HC712310	-
CODE UK			HA310701	HC512710	HC712710	HCD12710	HC512810	HC712810	HCD12810	HC512910	HC712910	HCD12910
MODEL			TX 10/16 STRADDLE	GX 12/25 STRADDLE	GX 12/35 STRADDLE	GX 12/38 STRADDLE	GX 12/25 PLUS STRADDLE	GX 12/35 PLUS STRADDLE	GX 12/38 PLUS STRADDLE	GX 12/25 GEL STRADDLE	GX 12/35 GEL STRADDLE	GX 12/38 GEL STRADDLE
CAPACITY	Q	Nominal load	kg	1000	1200	1200	1200	1200	1200	1200	1200	1200
CENTER OF GRAVITY	C	Distance	mm	600	600	600	600	600	600	600	600	600
DRIVING SYSTEM		Escort		●	●	●	●	●	●	●	●	●
DIMENSIONS												
ELEVATION	h3	Elevation	mm	1550	2450	3450	3750	2450	3450	3750	2450	3450
	h2	Normal free elevation	mm	1415	-	80	80	-	80	80	-	80
LENGTH	l	Fork length	mm	1000	1000	1000	1000	1000	1000	1000	1000	1000
	nxS1	Fork width x thickness	mm	100X35	100X35	100X35	100X35	100X35	100X35	100X35	100X35	100X35
DIMENSIONS	L	Total length	mm	1640	1715	1715	1715	1715	1715	1715	1715	1715
	L2	Steer unit length	mm	640	715	715	715	715	715	715	715	715
	B	Width	mm	750	850	850	850	850	850	850	850	850
	h1	Minimum dimensions	mm	1970	1780	2250	2427	1780	2250	2427	1780	2250
	A	Fork regulation (min/max)	mm	230-790	230-790	230-790	230-790	230-790	230-790	230-790	230-790	230-790
	B1	Maximum dimensions (min/max)	mm	1197-1504	1197-1504	1197-1504	1197-1504	1197-1504	1197-1504	1197-1504	1197-1504	1197-1504
	B2	Useful width for pallets (min/max)	mm	963-1270	963-1270	963-1270	963-1270	963-1270	963-1270	963-1270	963-1270	963-1270
	h4	Maximum dimensions	mm	2070	2985	3915	4310	2985	3915	4310	2985	3915
TURNINGS RADIUS	Wa		mm	1790	1460	1460	1460	1460	1460	1460	1460	1460
STOWAGE PASSAGE	Ast	800x1200	mm	2400	2116	2116	2116	2116	2116	2116	2116	2116
PERFORMANCES												
SPEED		Translation with/without load	km/h	-	4,0 / 5,0	4,0 / 5,0	4,0 / 5,0	4,0 / 5,0	4,0 / 5,0	4,0 / 5,0	4,0 / 5,0	4,0 / 5,0
		Lifting with/without load	m/s	0,09 / 0,12	0,07 / 0,10	0,07 / 0,10	0,07 / 0,10	0,07 / 0,10	0,07 / 0,10	0,07 / 0,10	0,07 / 0,10	0,07 / 0,10
		Descent with/without load	m/s	0,4 / 0,1	0,4 / 0,1	0,4 / 0,1	0,4 / 0,1	0,4 / 0,1	0,4 / 0,1	0,4 / 0,1	0,4 / 0,1	0,4 / 0,1
MAX SUPERABLE GRADIENT		With/without load	%	-	5 / 10	5 / 10	5 / 10	5 / 10	5 / 10	5 / 10	5 / 10	5 / 10
WEIGHTS												
EMPTY WEIGHT		With battery	kg	415	570	620	670	604	654	704	606	656
AXLE LOADING		With load (driver/load)	kg	453 / 962	584 / 1186	619 / 1201	658 / 1212	608 / 1196	643 / 1211	682 / 1222	606 / 1200	641 / 1215
		Without load (driver/load)	kg	270 / 145	382 / 188	428 / 192	466 / 204	406 / 198	452 / 202	490 / 214	404 / 202	450 / 206
FRAME												
WHEELS		Driver side/load	Nr	2/2	2+1 M/2	2+1 M/2	2+1 M/4	2+1 M/2	2+1 M/2	2+1 M/4	2+1 M/2	2+1 M/2
TYRES		Driver side/load	G / N	P+G/P	P+G/P	P+G/P	P+G/P	P+G/P	P+G/P	P+G/P	P+G/P	P+G/P
		Drive wheel dimensions	mmØ	-	250X76	250X76	250X76	250X76	250X76	250X76	250X76	250X76
		Stabilizer wheels dimensions	mmØ	200X50	150X40	150X40	150X40	150X40	150X40	150X40	150X40	150X40
		Load side dimensions	mmØ	82X70	82X70	82X70	82X70	82X70	82X70	82X70	82X70	82X70
WHEELS BASE	Y	Back/Front	mm	1130	1190	1190	1190	1190	1190	1190	1190	1190
	X		mm	246	255	255	255	255	255	255	255	255
OPERATING BRAKE		Mechanic(M) / Electric(E)		M	E	E	E	E	E	E	E	E
ELECTRICAL EQUIPMENT												
ELECTRIC MOTORS		Traction motor	kW	-	0,7	0,7	0,7	0,7	0,7	0,7	0,7	0,7
		Lifting motor	kW	1,6	2,2	2,2	2,2	2,2	2,2	2,2	2,2	2,2
SPEED CONTROL		Electronic	type	-	●	●	●	●	●	●	●	●
BATTERY		Traction(T) / starter(S)	S	S	S	T	T	T	T	T	T	T
		Voltage/capacity	V/Ah	12 / 74	2X12 / 92	2X12 / 92	2X12 / 92	2X12 / 110*	2X12 / 110*	2X12 / 110*	2X12 / 100**	2X12 / 100**
		Endurance	h	-	3	3	3	5	5	5	5	5
		Weight	kg	18	44	44	44	78	78	78	80	80
CHARGER		V-A		12-15	24-20	24-20	24-20	24-20	24-20	24-20	24-14	24-14

G=Rubber, P=Polyurethane

* Battery capacity of 132 Ah in 20 hours rating - ** Battery capacity of 125 Ah in 20 hours rating

ACCESSORIES	
POLYURETHANE DRIVING WHEEL RING	
CODE GX 12	HZ000S00005
DOUBLE LIFTING COMMAND	
CODE GX12	HZ000S00006

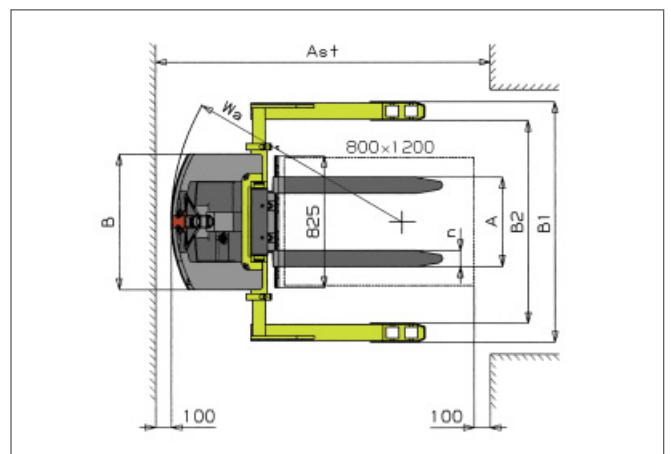
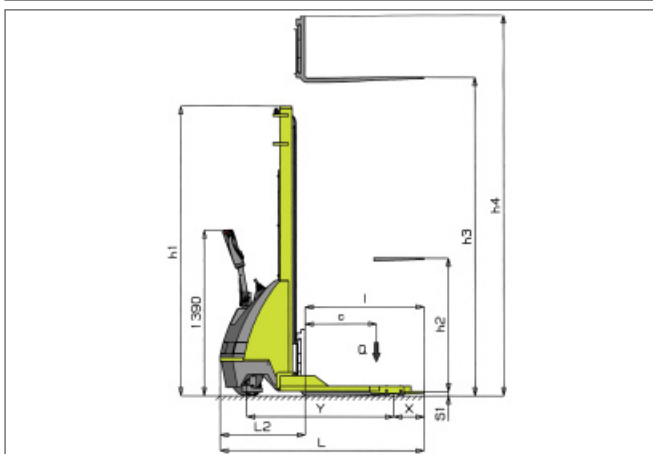

The producer reserves the right to introduce changes to models and features without prior notice.