

**Intelligent Weighing System**

The Scale Series is available in two different models, both with an intelligent weighing device with several options. Suitable for lifting and carrying heavy loads, this Series is not designed for “official” weighing but is extremely helpful for internal use.



**12 months warranty**

**GS/P 25 stainless**

The GS/P 25 model is also available in a Stainless Steel version ideal to be used in humid or damp conditions. It is suitable for all applications where high hygienic standards are enforced.



The central display allows a quick and simple reading of the carried weight. Its software allows not only weighing but also unit counting, adding and totalling of multiple loads, with serial number that can be stored within its memory.

**Display (GS/P25)**



CODE			GJB53000	GJB53S00	GHA33000	GJB530NN	GJB53SNN
MODEL			GS/P 25	GS/P 25 PRINTER	PX20	GS/P 25 STAINLESS	GS/P 25 STAINLESS PRINTER
CAPACITY	Load capacity	Kg	2500	2500	2000	2500	2500
DRIVING SYSTEM	Escort	type	●	●	●	●	●
BATTERY	Voltage / capacity (min-max)	V/Ah	6/1.1	6/1.1	6/1.1	6/1.1	6/1.1
WEIGHT	with battery	Kg	124	124	117	132	132
<b>DIMENSIONS</b>							
ELEVATION	Total elevation	mm	205	205	205	205	205
	Normal free elevation	mm	115	115	115	115	115
LENGTH	Fork length	mm	1180	1180	1180	1180	1180
	Fork width x thickness	mm	180x60	180x60	180x60	180x60	180x60
	Total Length	mm	1596	1596	1596	1596	1596
	Width	mm	555	555	555	555	555
TURNING RADIUS	Wa	mm	1426	1426	1426	1426	1426
STOWAGE PASSAGE	Ast	800x1200	mm	1846	1846	1846	1846
<b>WHEELS</b>							
	Driver/load side	Nr	2/4	2/4	2/4	2/4	2/4
	Driver/load side	*	G/P	G/P	G/P	G/P	G/P
<b>SCALE</b>							
	Accuracy	%	0,05	0,05	0,1	0,05	0,05
	Resolution	Kg	0,5	0,5	1	0,5	0,5
	Endurance	h	50	50	30	50	50
	Load cells	N°	4	4	4	4	4

\* G=Rubber, P=Polyurethane, N=Nylon

**PX20**

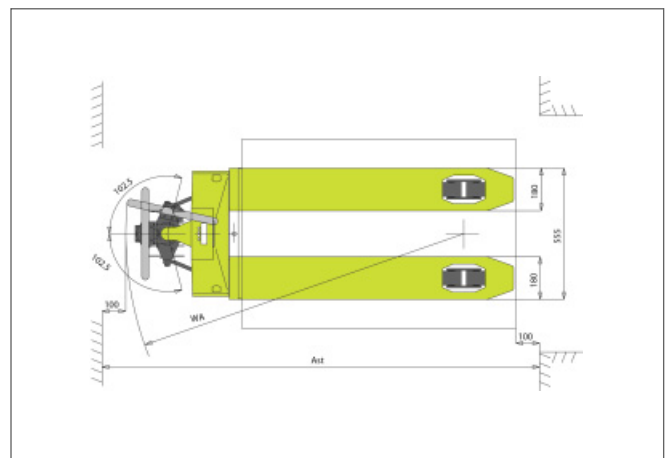
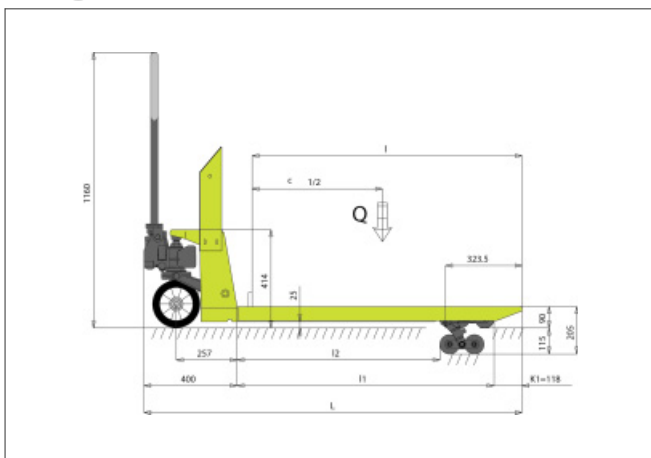

**GS/P25 - GS/P25 stainless**

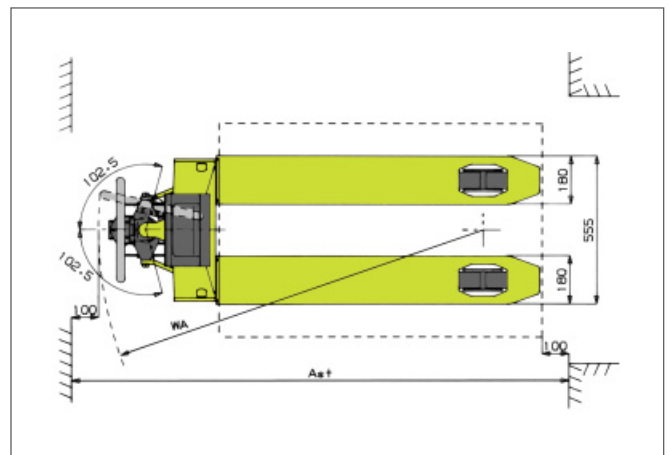
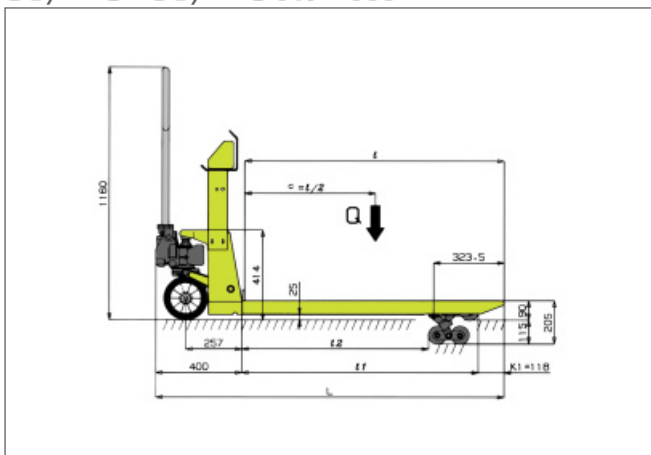

The producer reserves the right to introduce changes to models and features without prior notice.